

- ALL STEEL CONSTRUCTION—RINGS ARE .043 C.R.S.
- STEP DOWN DESIGN DEFLECTS AIR 360 DEGREES FOR HIGH AIR FLOW RATES
- FOR EASIER INSTALLATIONS USE OPTIONAL NO. 1900 DUCT RING OR NO. 1800 DUCT RING WITH BUTTERFLY DAMPER
- FINISH: WHITE (W) ENAMEL

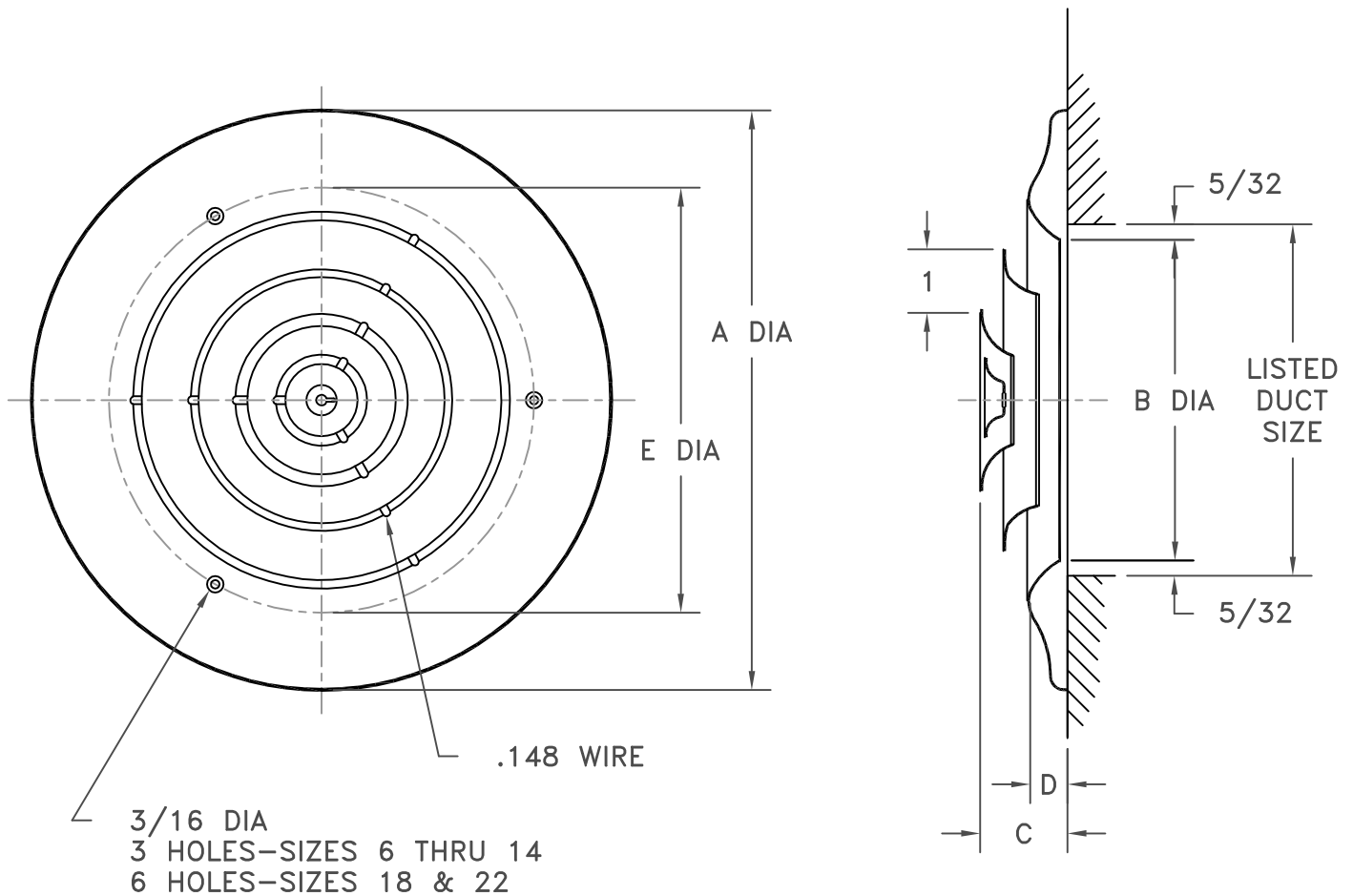

SIZE	A DIA	B DIA	C	D	E DIA
6	9-15/16	5-11/16	1-3/64	11/16	6-1/2
8	11-15/16	7-11/16	1-7/32	11/16	8-1/2
10	13-15/16	9-11/16	1-25/64	11/16	10-1/2
12	15-15/16	11-11/16	1-9/16	11/16	12-1/2
14	17-15/16	13-11/16	1-3/4	11/16	14-1/2
18	23	17-11/16	2-19/32	15/16	21-3/4

JOB NAME: _____
 LOCATION: _____
 ARCHITECT: _____
 ENGINEER: _____
 CONTRACTOR: _____

SUBMITTED BY: _____

DATE: 04/17/2013 | AMF-31

1500
 Steel Round Diffuser
 Step Down Face