

- EXTRUDED ALUMINUM CONSTRUCTION
- STYLES WITH FRONT BANK VERTICAL:
 - RA192L SINGLE DEFLECTION GRILLE
 - RA191VH DOUBLE DEFLECTION GRILLE
 - RA190VH DOUBLE DEFLECTION WITH DAMPER
- BARS ARE ON 3/4 INCH CENTERS AND INDIVIDUALLY ADJUSTABLE
- CHANNEL BRACE IS ADDED WHEN EITHER DIMENSION IS 48 INCHES OR OVER
- SCREW HOLE LOCATIONS STANDARD UNLESS OTHER WISE SPECIFIED
- FOR SCREW HOLE LOCATIONS SEE AMF-41
- MINIMUM SIZE: 6 X 4
- MAXIMUM SIZE: 72 X 48 OR 48 X 96 ONE PIECE CONSTRUCTION
- AVAILABLE IN 1 INCH INCREMENTS
- FINISH: WHITE (W) ENAMEL
- Z-FRAME AVAILABLE SPECIAL ORDER ONLY

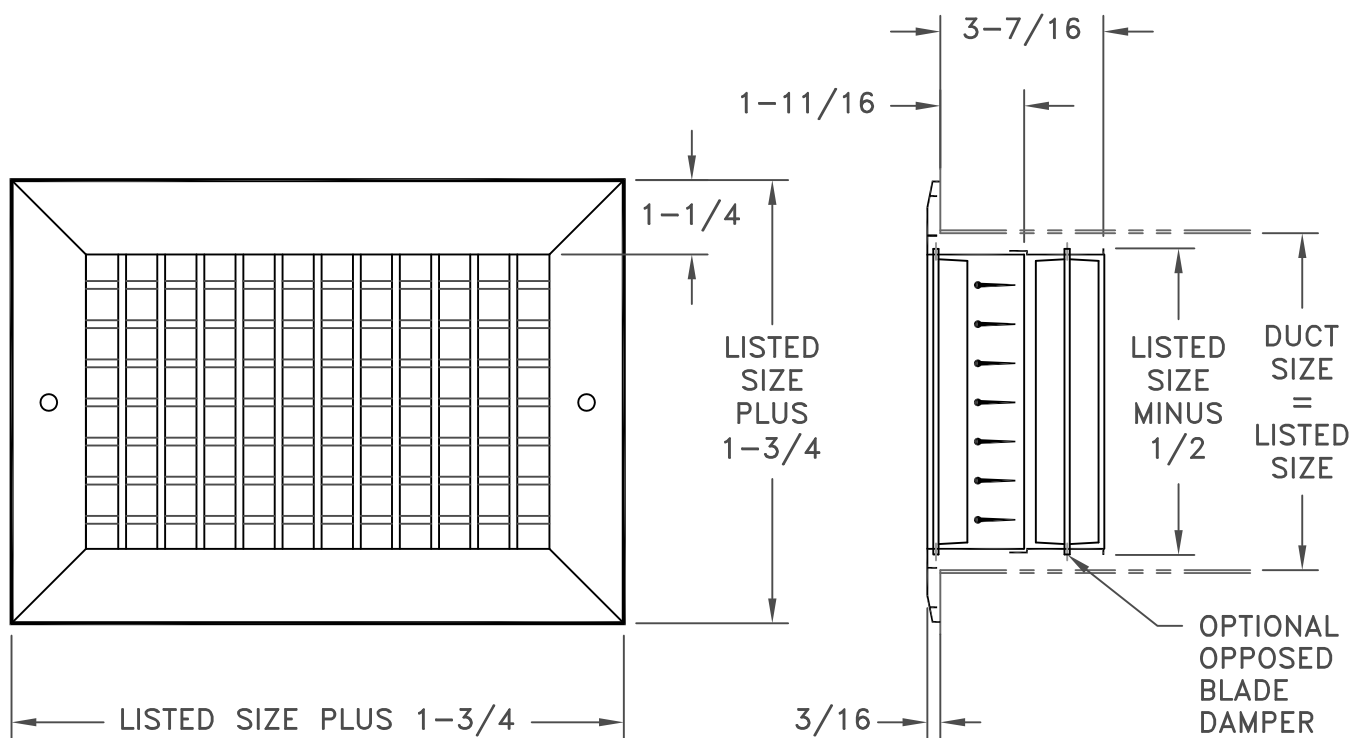

RA190VH DOUBLE DFL W/DAMPER

JOB NAME: _____
 LOCATION: _____
 ARCHITECT: _____
 ENGINEER: _____
 CONTRACTOR: _____

SUBMITTED BY: _____

DATE: 04/21/2017 | AMF-39

RA SERIES
 Extruded Aluminum Grilles And
 Registers Adjustable Vertical
 And Horizontal Face Bars